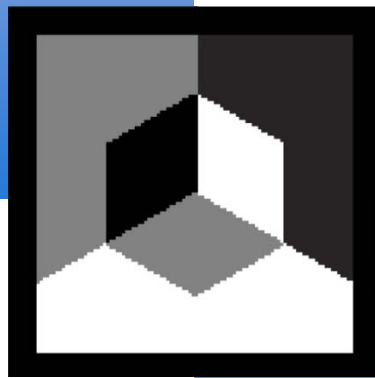


FMA/AAMA 100-12

**Standard Practice for the  
Installation of Windows  
with Flanges or Mounting  
Fins in Wood Frame  
Construction for Extreme  
Wind/Water Conditions**





# TABLE OF CONTENTS

FOREWORD .....	1
1.0 SCOPE .....	1
2.0 REFERENCED PUBLICATIONS .....	2
3.0 DEFINITIONS .....	2
4.0 SIGNIFICANCE AND USE .....	4
5.0 RELATED ISSUES AND PROCEDURES .....	4
6.0 WINDOW PRE-INSTALLATION PROCEDURES .....	5
7.0 WINDOW INSTALLATION PROCEDURES .....	6
8.0 POST INSTALLATION PROCEDURES .....	19
9.0 KEYWORDS .....	19
APPENDIX A .....	20



© 2012 Fenestration Manufacturers Association and American Architectural Manufacturers Association. All rights reserved. These printed or electronic pages may NOT be reproduced, republished and distributed in any format without the express written consent of the American Architectural Manufacturers Association (AAMA) and the Fenestration Manufacturers Association (FMA).

“This document was developed by representative members of AAMA and FMA as advisory information and published as a public service. AAMA AND FMA DISCLAIM ALL WARRANTIES WITH REGARD TO THIS INFORMATION, INCLUDING ALL IMPLIED WARRANTIES OF MERCHANTABILITY AND FITNESS. IN NO EVENT SHALL AAMA OR FMA BE LIABLE FOR ANY DAMAGES WHATSOEVER FROM THE USE, APPLICATION OR ADAPTATION OF MATERIALS PUBLISHED HEREIN. It is the sole responsibility of the user/purchaser to evaluate the accuracy, completeness or usefulness of any information, opinion, advice or other content published herein.”

FMA/AAMA 100-12  
ORIGINALLY PUBLISHED: 2007  
PRECEDING DOCUMENT: FMA/AAMA 100-07  
PUBLISHED: 7/12

**Fenestration Manufacturers Association (FMA)**  
11445 Moccasin Gap Road, Tallahassee, FL 32309,  
PHONE (850) 668-8813 FAX (850)224-5283  
WEBSITE: [www.fmausaonline.org](http://www.fmausaonline.org)

**American Architectural Manufacturers Association**  
1827 Walden Office Square, Suite 550, Schaumburg, IL 60173  
PHONE (847) 303-5664 FAX (847) 303-5774  
EMAIL: [customerservice@aamanet.org](mailto:customerservice@aamanet.org) WEBSITE: [www.aamanet.org](http://www.aamanet.org)

---

## FOREWORD

---

This standard practice includes procedures for the installation of windows into residential and light commercial buildings of not more than three stories above grade in height. This standard practice presumes a membrane/drainage plane is present behind the facade.

The techniques demonstrated in this standard practice have been developed specifically to allow incidental liquid water entering from superficial cracks, either in the cladding, window joinery or installation joints around the perimeter of the window, to drain onto the membrane drainage plane and to exit to the building exterior.

This standard is specifically designed for installations subject to extreme wind/water climate exposure, particularly in the coastal southeast United States, and addresses buildings that will be at high risk for water intrusion. Thus, preventative measures shall be taken that are above normal installation practices (such as those referenced in ASTM E2112).

---

## 1.0 SCOPE

---

**1.1** This standard practice covers the installation of windows in wood frame new construction residential and light commercial buildings of not more than three stories above grade in height, utilizing a membrane/drainage system. It is expected that all referenced components shall meet code requirements in force at the time of installation.

**1.2** To simulate extreme exposure conditions and demonstrate the effectiveness of the standard practice, installation methods that are consistent with this document have been water tested up to a test pressure of 575 Pa (12 psf) using the ASTM E547 or E331 water test. This does not advocate field or lab testing to those levels as a requirement for this standard practice.

**1.3** This practice applies to windows which employ a mounting flange, or fin that is attached to the window perimeter frame and is designed as an installation appendage.

**1.4** This standard practice covers the installation process for windows from pre- to post-installation. It does not include factory or field fabrication techniques that would be required to join individual windows to each other, either horizontally or vertically.

**1.5** This standard practice provides recommended requirements for window installation based on current best practices. If the window manufacturer provides installation instructions, the manufacturer's instructions shall take precedence.

**1.6** This standard practice provides installation instructions to enhance water management performance of the interface of the window with the opening.

**1.7** This standard practice does not address safety concerns, either from the installation process or those that may be present at the building site. It shall be the responsibility of the user of this standard practice to ensure that all appropriate health and safety practices have been implemented.

**1.8** Accessibility requirements (such as ADA) are beyond the scope of this standard practice.

**1.9** Consult the manufacturer for installation instructions to enhance water management performance of the interface of the window system with the opening.

**1.10** This standard practice does not address issues with drainage requirements of adjacent cladding or with integrating drainage requirements of the installation with the adjacent cladding. In all circumstances, the General Contractor is expected to follow best practices for integration with membrane/drainage wall systems.

**1.11** This document was developed in an open and consensus process and is maintained by representative members of FMA and AAMA as advisory information.

---

## 2.0 REFERENCED PUBLICATIONS

---

**2.1** References to the standards listed below shall be to the edition indicated. Any undated reference to a code or standard appearing in the requirements of this standard shall be interpreted as referring to the latest edition of that code or standard.

### 2.2 AMERICAN ARCHITECTURAL MANUFACTURERS ASSOCIATION (AAMA)

**AAMA 711-07**, Voluntary Specification for Self Adhering Flashing Used for Installation of Exterior Wall Fenestration Products

**AAMA 712-11**, Voluntary Specification for Mechanically Attached Flexible Flashing

**AAMA 714-12**, Voluntary Specification for Liquid Applied Flashing Used to Create a Water-Resistive Seal around Exterior Wall Openings in Buildings

**AAMA 713-08**, Voluntary Test Method to Determine Chemical Compatibility of Sealants and Self-Adhered Flexible Flashings

**AAMA 800-10**, Voluntary Specifications and Test Methods for Sealants

**AAMA 812-04(2010)**, Voluntary Practice for Assessment of Single Component Aerosol Expanding Polyurethane Foams for Sealing Rough Openings of Fenestration Installations

### 2.3 ASTM INTERNATIONAL (ASTM)

**ASTM C794-10**, Standard Test Method for Adhesion-in-Peel of Elastomeric Joint Sealants

**ASTM C920-11**, Standard Specification for Elastomeric Joint Sealants

**ASTM C1281-03(2009)**, Standard Specification for Preformed Tape Sealants for Glazing Applications

**ASTM E331-00(2009)**, Standard Test Method for Water Penetration of Exterior Windows, Skylights, Doors, and Curtain Walls by Uniform Static Air Pressure Difference

**ASTM E547-00(2009)**, Standard Test Method for Water Penetration of Exterior Windows, Skylights, Doors, and Curtain Walls by Cyclic Static Air Pressure Difference

**ASTM E2112-07**, Standard Practice for Installation of Exterior Windows, Doors and Skylights

### 2.4 ICC EVALUATION SERVICE (ICC ES)

**AC 38-2004**, Acceptance Criteria for Weather-Resistive Barriers

---

## 3.0 DEFINITIONS

---

**AIR SEAL**, *n.* – A continuous seal put into the air gap area around the interior side, exterior side or both sides of the window perimeter to restrict infiltration or exfiltration of air past the fenestration product.

**BACK DAM**, *n.* – The rear upturned leg of a masonry sill, sill pan or subsill designed for the purpose of diverting liquid water. A sealant joint can also be used to form a back dam provided it is part of a continuous air seal.

**BUILDING PAPER**, *n.* – A membrane material made of cellulose paper impregnated with asphalt (to inhibit passage of liquid water through the material) and which is commonly used as a concealed water-resistive barrier (WRB), similar to polymer house wraps, in membrane/drainage walls.

**COMPATIBILITY**, *n.* – When materials maintain physical and functional properties when in direct contact or close proximity to each other.

**END DAM**, *n.* – Any means provided to stop the flow of water out of the ends of a sill, panning system or subsill and into the wall cavity, such as sealant, upstands, plates or gasketing. End dams shall be of a height equal to the height of the back dam or higher.

**FRONTAL FLANGE (A.K.A. FLANGE)**, *n.* – Refers to a type of window which includes a permanent appendage projecting parallel to the plane of the wall, located at or near the exterior surface of the window for the purpose of installing the window against a backstop, buck, receptor or other such stepped features that have been incorporated into the rough opening.

**FLASHING**, *n.* – Water resistant material that bridges the joint between the window/door frame and the adjacent construction to prevent water penetration. See *Mechanically Attached Flashing*, *Self Adhering flashing*, *Pan Flashing*.

**HOUSE WRAP**, *n.* – A polymer-based sheet material provided in a variety of dimensions and used as a water-resistive barrier (WRB) (Users of this product should defer to manufacturer's instructions).

**MECHANICALLY ATTACHED FLASHING**, *n.* – Flashing (as defined above) which is permanently attached using screws, staples or other mechanical fasteners. Mechanically attached flashing shall meet the performance requirements of AAMA 712.

**MEMBRANE/DRAINAGE SYSTEM**, *n.* – A wall system employing a concealed water-resistive barrier in which the exterior building surface, e.g., stucco, brick veneer, siding, is not the sole method of protecting the building from moisture penetration.

**MOUNTING FLANGE (A.K.A. MOUNTING FIN, INTEGRAL FIN)**, *n.* – An appendage protruding from the body of a window or door frame, used as either an installation attachment feature or part of the water-resistive barrier interface between the product and the wall, or both.

**PAN FLASHING (A.K.A. SILL PAN)**, *n.* – A type of flashing used at the base of a rough opening to divert water to the exterior or to the exterior surface of a concealed WRB. Pan flashings have upturned legs at the rear interior edge (back dam) and right and left sides (end dams), to form a three-sided pan that has the front open for drainage. They are intended to collect and drain water toward the exterior, including water that may enter through the window unit or around the window (between the rough opening and the fenestration).

**DISCUSSION:** *The pan flashing must be integrated with other flashings and the window assembly to capture water that may otherwise penetrate to the sill framing and allow it to freely drain to the exterior. For this reason, sill pans shall not be sloped to the interior. For this reason, sill pans shall not be sloped to the interior. The window, flashings and pan flashing must be sealed in a manner that reliably inhibits air and moisture flow to the interior.*

Pan flashing can be made from self-adhered flashing or from rigid or semi-rigid material, such as metal or a semi-rigid polymer.

**SEALANT (CONSTRUCTION)**, *n.* – Any of a variety of compounds used to fill and seal joints or openings. For the purpose of this standard practice, sealant shall have the capability of allowing for joint movement and appropriate adhesion as required for construction applications.

**SEALANT, AEROSOL FOAM**, *n.* – In building construction, a sealant that expands in volume as it is dispensed from a container, using propellant under pressure, to form a rigid or semi-rigid cellular mass.

**SELF ADHERING FLASHING**, *n.* – Flashing (as defined above) which is coated completely or partially on at least one side with an adhesive material and which do not depend on mechanical fasteners for permanent attachment.

**SHIM**, *n.* – A material used to raise, level or plumb a fenestration product frame during installation.

**WATER-RESISTIVE BARRIER (WRB)**, *n.* – The surface or surfaces of a wall system which complies with ICC AC38 and is responsible for preventing water infiltration to the building interior. A membrane, which can be a house wrap or building paper, whose primary function is to act as a drainage plane for liquid water, which has a permeance low enough to keep liquid water from penetrating through the surface.

---

## **4.0 SIGNIFICANCE AND USE**

---

**4.1** This standard practice recognizes that the effective performance of installed window products is highly dependent upon following proper installation procedures, using appropriate materials, and quality workmanship.

**4.2** This standard practice recognizes that the coordination of trades and proper sequencing are essential for effective window installation. Responsibilities of trades are outlined in Appendix A. The general contractor shall be responsible for the necessary coordination of trades and proper construction sequencing of the installed fenestration product.

**4.3** This standard practice recognizes that improper installation of units may contribute to excessive air infiltration, water penetration, sound leakage, insufficient structural integrity and condensation.

**4.4** This standard practice presumes the installer/contractor has a working knowledge of applicable federal, state and local codes and regulations; specifically, but not limited to required means of egress, requirements for safety glazing materials and structural requirements based on the applicable codes.

**4.5** This standard practice presumes the installer has a working knowledge of the tools, equipment and methods necessary for the installation of specified fenestration products. It further requires the installer to have familiarity with flashing and sealing techniques, application of caulking and sealants, finishes (where applicable), and an understanding of the fundamentals of construction that affect the installation of these units, including their compatibility with other materials.

**4.6** This standard practice presumes that the products supplied have been furnished for the applicable installation and that their locations within the structure have been pre-determined to comply with all the applicable building codes and regulations.

---

## **5.0 RELATED ISSUES AND PROCEDURES**

---

### **5.1 CONTINUITY**

Continuity shall be maintained between all elements of the surrounding wall and the window product and the water-resistive barrier.

### **5.2 JOINTS AND ANCHORAGES**

Joints and anchorages between the building envelope (water-resistive barrier assembly) and window shall be designed to accommodate differential thermal expansion and contraction, as well as the structural requirements within the window/wall assembly.

### **5.3 CONSTRUCTION DAMAGE**

The building shall be constructed in such a manner as to secure or support the installation materials, including the flashing and water resistive barrier. The walls shall not be left unprotected or uncovered without cladding for longer than recommended by the WRB / flashing manufacturer. The installed water-resistive barrier and flashing shall be protected from damage during construction. Any damage to the water-resistive barrier or flashing created during the installation shall be repaired prior to completing the installation of the window and/or applying the exterior cladding.

### **5.4 SEALANT SELECTION**

Prior to using sealant, the general contractor, design professional or builder shall seek input from the sealant manufacturer regarding sealant selection. This includes proper joint design, material (chemical) compatibility, and proper adhesion to the substrates that the sealant will be in contact with.

#### **5.4.1 Chemical Compatibility**

All materials, such as, but not limited to coatings, flashings and sealants that come into contact with each other shall exhibit chemical compatibility, per AAMA 713.

#### **5.4.2 Adhesion of Sealants**

Adhesion of sealants to the substrates they will contact shall be verified by the sealant manufacturer peel adhesion per ASTM C794.

### **5.4.3 Sealant Joint Design**

The design professional, general contractor or builder shall consult with the sealant manufacturer to ensure the sealant joint is designed to accommodate the joint gap and expected joint movement between window and the wall opening for the intended purpose.

### **5.4.4 Sealant Performance Specifications**

Gunnable sealants shall comply with AAMA 808.3 per AAMA 800 Section 1.4 or ASTM C920 Class 25 Grade NS or greater for proper joint expansion and contraction. If preformed tapes are used, they shall meet ASTM C1281. If low expansion foams are used, they shall be tested in accordance with AAMA 812.

**5.4.5** Self adhering flashing shall meet the performance requirements of AAMA 711.

**5.4.6** Liquid applied flashing shall meet the performance requirements of AAMA 714.

### **5.5 STUCCO AND OTHER CLADDING**

Stucco and other cladding shall not be installed prior to window installation.

### **5.6 SHIMS**

Shims shall be installed between the window frame and the rough opening in such a manner to support the product in a plumb, level, square and true position.

---

## **6.0 WINDOW PRE-INSTALLATION PROCEDURES**

---

### **6.1 ROUGH OPENINGS**

**6.1.1** Size and tolerances of the rough openings shall be determined from the window manufacturer's instructions and this standard practice. Remedy any discrepancies.

**6.1.2** The rough opening shall be plumb level, square, and true prior to the installation of the window. No more than 6 mm (1/4 in) deviation from square, height, and width and 3 mm (1/8 in) deviation from plumb shall be allowed, unless otherwise specified by the manufacturer's instructions.

### **6.2 WATER-RESISTIVE BARRIERS (WRB)**

This standard practice recommends that the WRB be installed prior to the window installation. The installation method described in this standard practice is based on this sequence. In the event that the WRB is installed after the window installation, refer to ASTM E2112 for various sequencing considerations.

**6.2.1** The application of the WRB involves covering the vertical surfaces of the wall, lapped, fastened, taped, and sealed per the WRB manufacturer's instructions.

**6.2.2** Penetrations through the WRB for the installation of windows shall be made in accordance with the WRB manufacturer's recommendations or this standard practice.

**6.2.3** The WRB shall be applied in water shedding fashion, starting at the base of the wall and working towards the top. The WRB shall be applied to the face of the building framing or sheathing.

**6.2.4** Under extreme wind/water exposure, it is possible that incidental water that migrates behind the WRB due to penetrations, fasteners, or cladding attachment and may migrate into the window rough opening. While these other WRB penetrations are outside the scope of this standard practice, it is recommended that steps are taken to mitigate this potential incidental water intrusion by creating a water seal between the WRB and sheathing at the window rough opening.

### **6.2.5 Two Layer WRB Systems**

If required, a two-layer WRB or building paper (BP) system shall be used in accordance with state and local codes. The window shall be flashed/integrated with inner layer WRB.

## 6.3 PRE-WINDOW-INSTALLATION INSPECTION

**6.3.1** Before window installation, the installer shall inspect the WRB to ensure that it is installed in accordance with this standard practice and the WRB manufacturer's instructions. Any tears, penetrations or defects within 305 mm (12 in) of the rough opening area shall be sealed per the WRB manufacturer's instructions.

**6.3.2** The installer shall verify that the rough opening is plumb, level, square, and true. The installer shall notify the contractor to remedy any discrepancies per this standard practice.

**6.3.3** Installer shall inspect the fenestration product for damage and repair or replace if necessary.

---

## 7.0 WINDOW INSTALLATION PROCEDURES

---

### 7.1 PREPARATION OF WRB

This practice recommends that the underside of the WRB be sealed at the rough opening, per discussion in Section 6.2.4. There are a variety of ways to do this successfully. Three representative methods are as follows:

#### 7.1.1 WRB Method A

Box cut WRB around rough opening, seal with 100 mm or 150 mm (4 in or 6 in) self-adhered flashing between the jamb corner at the head, such that self-adhered flashing covers 50 mm (2 in) on the WRB as well as into the rough opening return at least to the depth of the window, and the sill (see Figure 1). Apply sealant at jamb/head interface (see Figure 2). See Schematic 1 for jamb detail.

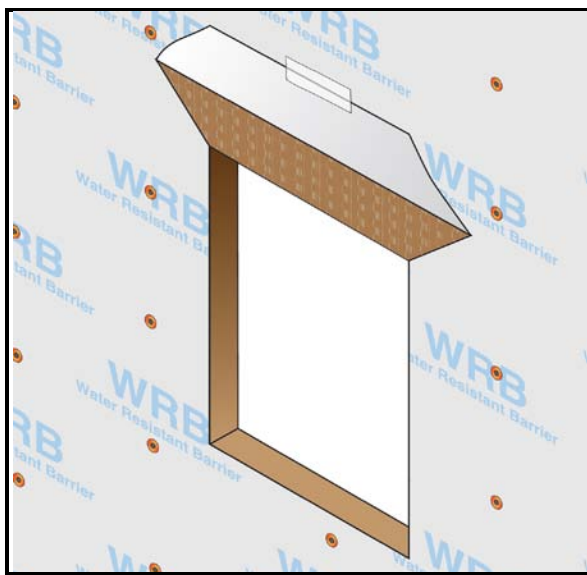


FIGURE 1

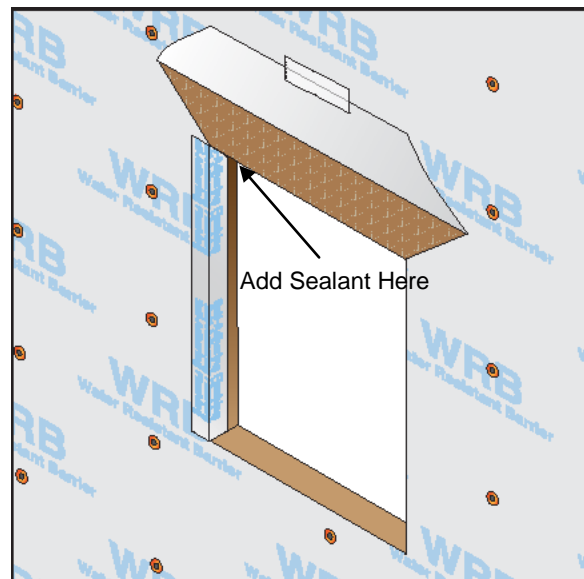
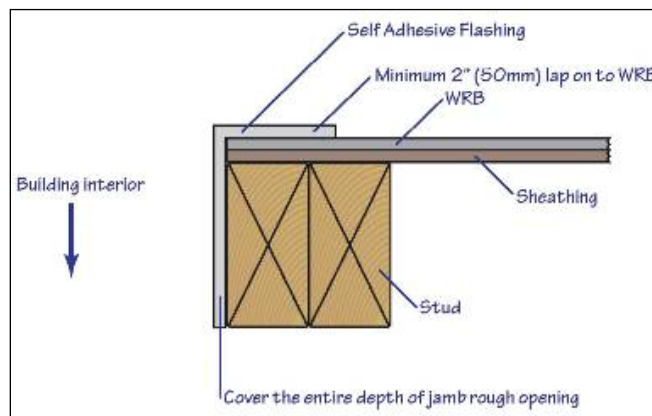


FIGURE 2



Schematic 1 (Top View)



### 7.1.2 WRB Method B Integration after Window is Installed (per Section 7.3.6)

Box cut WRB around rough opening and make cut 150 mm (6 in) onto the face of the wall at each jamb corner and fold back jamb as with head flap ensuring that the jamb cuts at the sill are angled upwards (Figure 3). After the window is installed (per Section 7.3.6), apply sealant along jamb and fold over the previously folded over WRB jamb flap allowing it to integrate with the window frame (see Figures 4 and 4A). Press down on sealant bead under WRB. Integrate WRB to the window with sheathing tape or self-adhering flashing. See Schematic 2 for jamb detail.

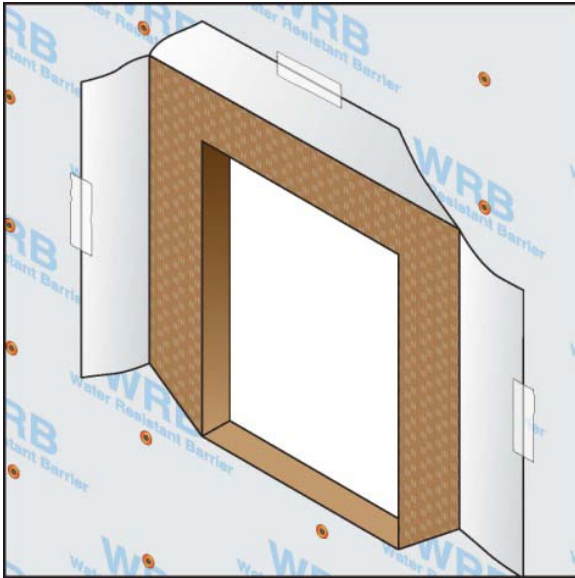


FIGURE 3

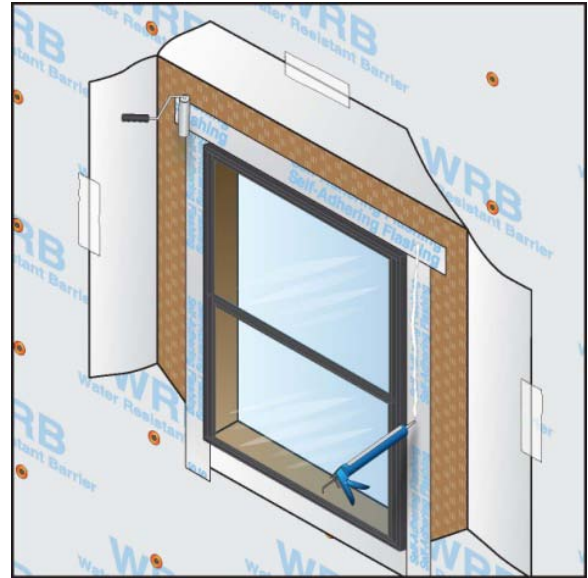
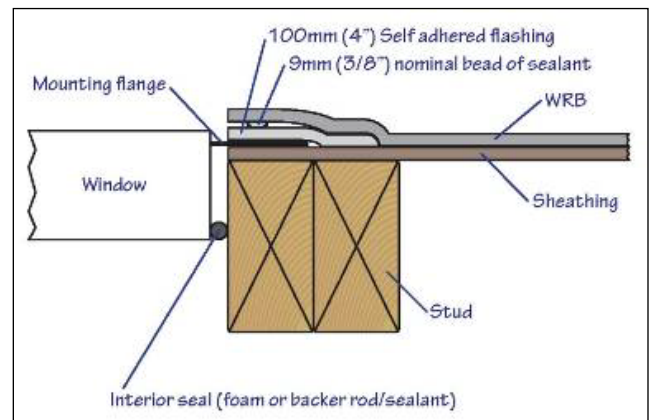


FIGURE 4



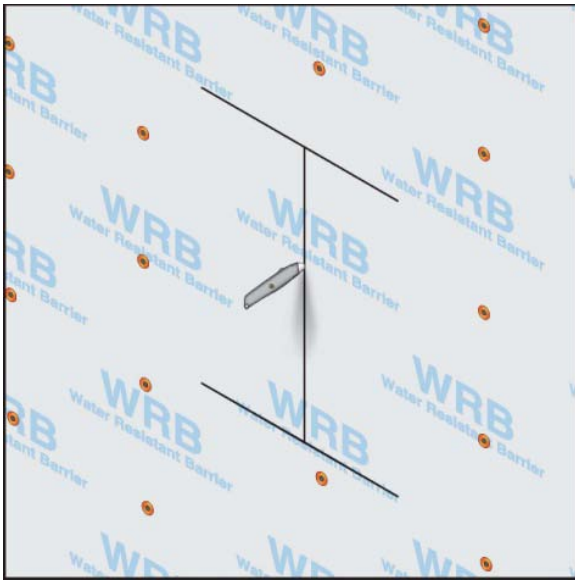
FIGURE 4A



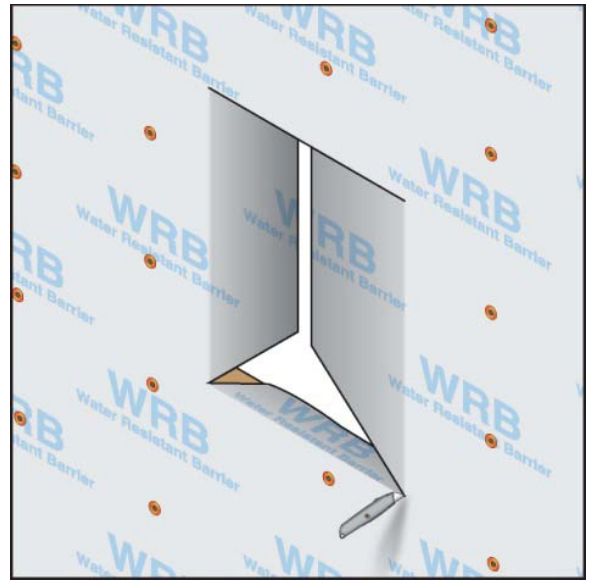
SCHMATIC 2

### 7.1.3 WRB Method C

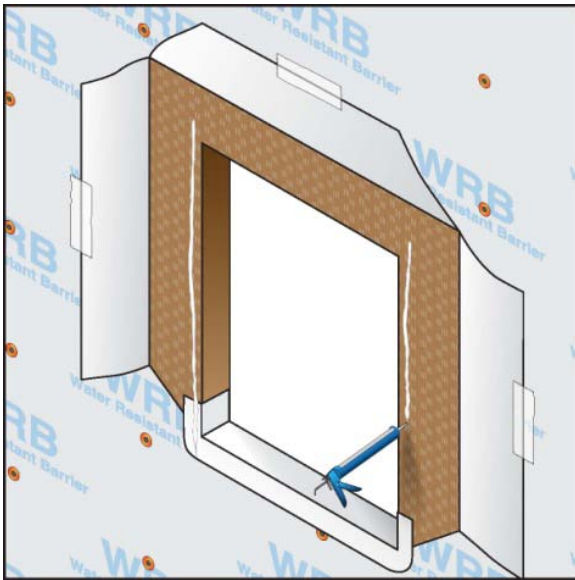
Full I-Cut of WRB (see Figure 5) or modified I-Cut (Figure 5A), Apply sealant onto sheathing under WRB at jambs (Figure 6), and wrap into cavity and secure (Figure 7). Attach the WRB into position on the inside of the rough opening, and trim any excess as required (Figure 8). Press down on sealant bead below WRB. See Schematic 3 for jamb detail.



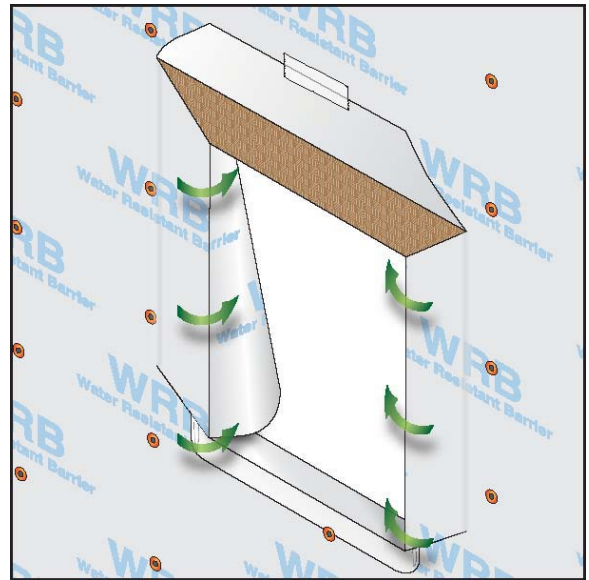
**FIGURE 5**



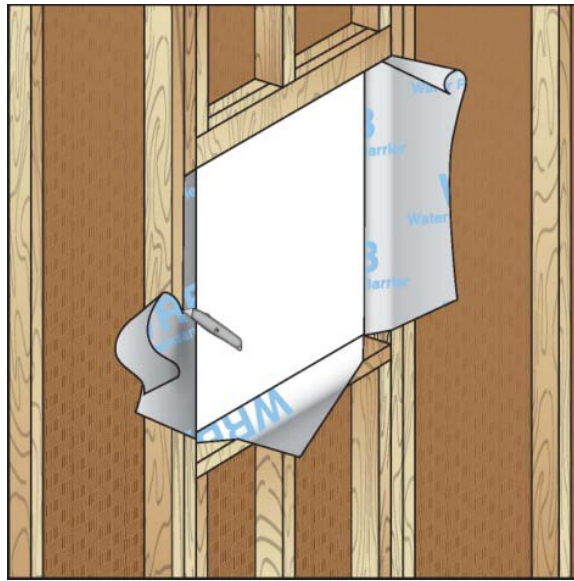
**FIGURE 5A**



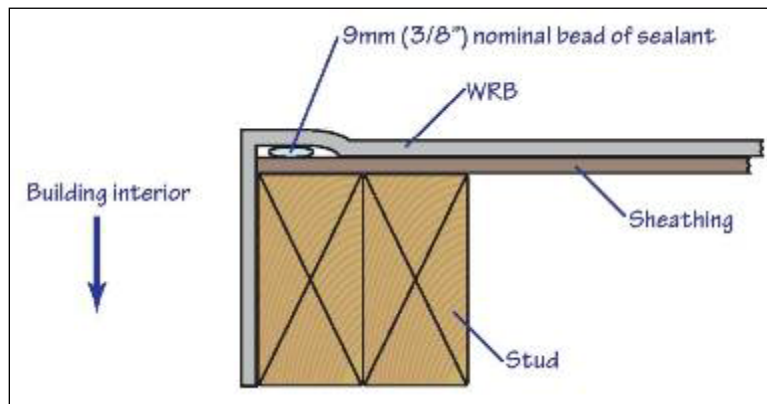
**FIGURE 6**



**FIGURE 7**



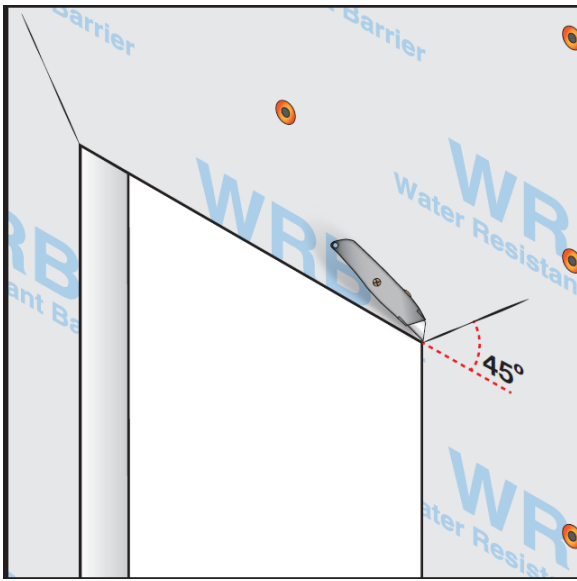
**FIGURE 8**



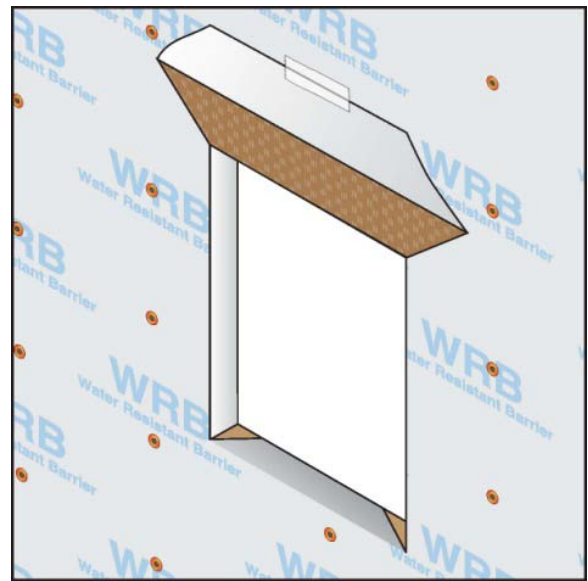
**SCHEMATIC 3**

**7.1.4 For all WRB Wrap methods**

At the head of the opening, starting at the top corner of the exterior window (rough) opening, measure from the corner horizontal and then vertical a distance equal to the roll width of the flashing to be applied. At a 45° angle, carefully cut the WRB on a diagonal (see Figure 9). Repeat this step on the opposite corner. Trim 25 mm (1 in) off the bottom of the WRB head flap for proper integration with the head flange of the window. Raise the bottom edge of the flap created in the WRB up and temporarily tape to the exterior face of the WRB above (Figure 10). This is done in order to allow for installation of the exterior window and head flashing later.



**FIGURE 9**



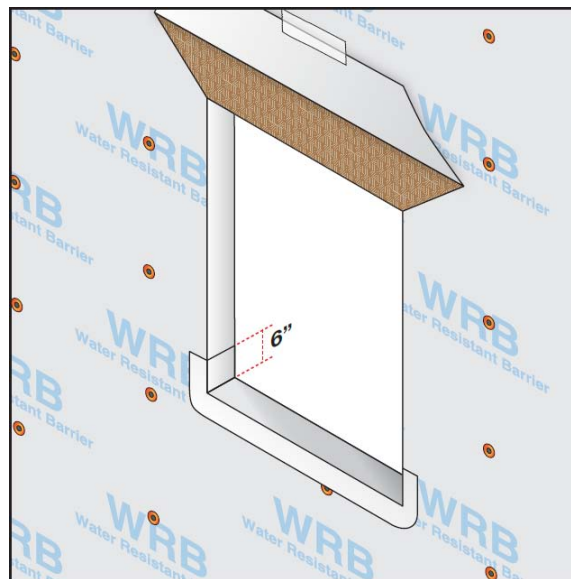
**FIGURE 10**

## 7.2 APPLYING A SILL PAN FLASHING

**7.2.1** Ensure that the rough opening wood sill area is clean and free of debris.

**7.2.2** There are a variety of sill pan systems available. The pan flashing shall direct water to the exterior or to the membrane drainage plane for subsequent drainage to the exterior of the building.

**7.2.3** When self-adhering flashing is used as a sill pan, cut to a length equal to the rough opening width plus at least 300 mm (12 in), such that 150 mm (6 in) minimum is used at each jamb to form end dams (See Figure 11).



**FIGURE 11**

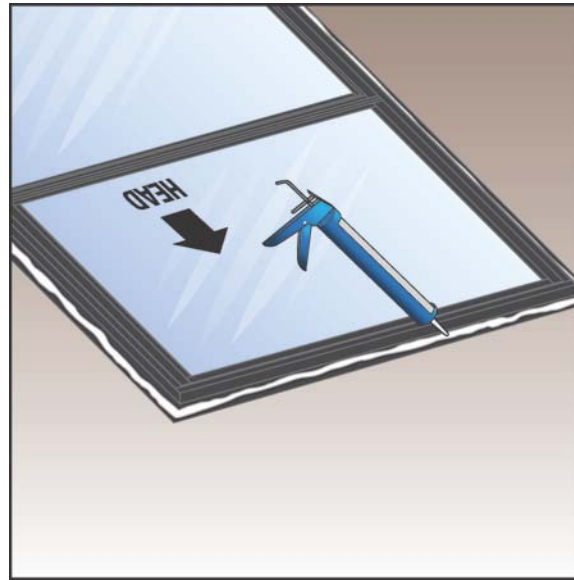
The self-adhering flashing sill pan system shall cover the sill to at least the depth of the window, plus at least 50 mm (2 in), but not more than 75 mm (3 in), which shall lap onto the face of the WRB drainage plane. The 75 mm (3 in) maximum is specified to ensure that jamb flashing of 100 mm (4 in) width will adequately lap over the sill flashing.

**7.2.4** If a rigid or semi-rigid sill pan system is used, follow the manufacturer's instructions for installation details and integration with the WRB and flashing.

### 7.3 INSTALLATION OF WINDOW INTO ROUGH OPENING

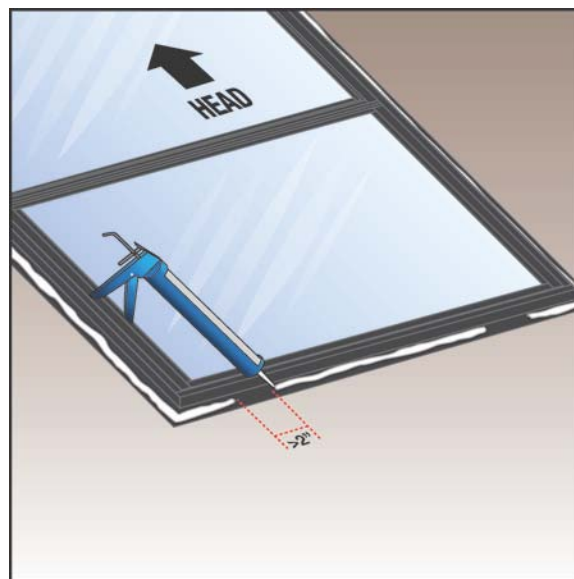
**7.3.1** Inspect and clean the back side (interior surface) of the exterior window mounting flange. Look for any sealant gaps or misaligned welding (particularly for vinyl products) at the corner joinery. If corner seals of the flange are missing in whole or part, contact the window manufacturer for the recommended remedy.

**7.3.2** After cleaning the mounting flange, carefully run a continuous 9 mm (3/8 in) nominal diameter bead of sealant on the back surface (interior face) of the mounting fin (see figure 12) of window at the head and both jambs. Apply sealant in line with any pre-punched holes or slots in the mounting flange. Connect that bead of sealant across any joinery on the window frame at all four corners. As an option, the sealant shall be permitted to be applied to the wall surface as opposed to the back of the mounting flange.



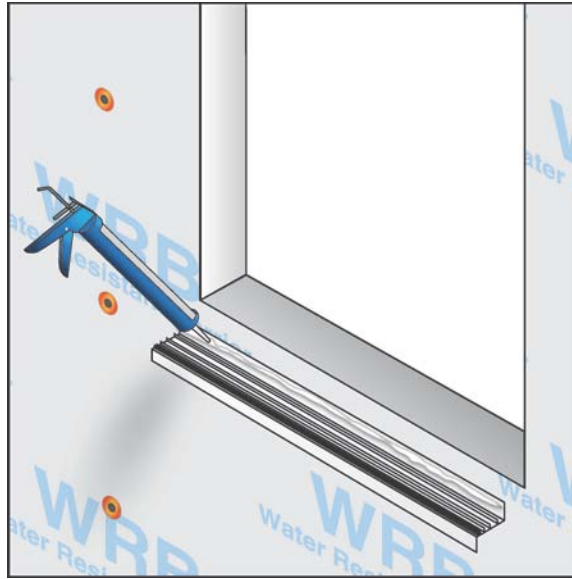
**FIGURE 12**

**7.3.3** Apply a discontinuous bead of sealant on the interior surface of the mounting flange at the sill. The bead of sealant shall be discontinuous, leaving two 50 mm (2 in) voids within 100 mm (4 in) of each jamb (see Figure 13). Any alternative to the discontinuity in the bead of sealant at the exterior sill area shall be approved by the window manufacturer.



**FIGURE 13**

**7.3.4** If a rigid or semi-rigid sill pan is used, apply a continuous bead of sealant to the outboard side of the upturned leg of the pan where it will integrate with the interior side of the window and form an air/water seal (Figure 14).



**FIGURE 14**

**7.3.5** Immediately set the window in the opening (see Figure 15).



**FIGURE 15**

**7.3.6** Hold the window temporarily into position and apply shims as required to ensure the window is set plumb, level, square and true. Fasten the window perimeter securely into position in accordance with the manufacturer's instructions.

**NOTE 1:** Additional fasteners may be required at locations such as locking mechanism or hinges, per manufacturer's instructions.

**7.3.6.1** For proper sealant coverage, ensure squeeze out under flange and in fastener holes (see Figure 16).

**7.3.7** Install shims in such a manner that they are not permitted to interfere with the application of the air seal; which will be applied on the interior side in the steps that follow.



**FIGURE 16**

**NOTE 2:** In the following two sections: either self-adhesive flashing (see Section 7.4) or mechanically attached flashing (see Section 7.5) shall be permitted to be used for jamb and head flashing, per the following steps.

**7.4 JAMB AND HEAD FLASHING INSTALLATION USING SELF ADHERING FLASHING.**

**7.4.1** Apply flashing over the mounting flange of the window at both jambs per manufacturer’s instructions. The self-adhering flashing shall conform to the requirements of AAMA 711 and be a minimum of 100 mm (4 in) in width.

**NOTE 3:** Local job site conditions, application temperatures, or specific materials may require the application of primer to any exposed wood as required by the flashing manufacturer.

**7.4.2** Cut the jamb flashing to a measurement equal to twice the roll width of the flashing being used, plus the height of the rough opening, minus 25 mm (1 in) and apply onto window jamb (see Figure 17).



**FIGURE 17**

**7.4.3** Adhere the top end of the flashing 50 mm (2 in) above the rough opening, such that the head flashing (applied later) will lap over the jamb flashing by at least 50 mm (2 in) (see Figure 17).

Do not interfere with the WRB flap at the head. Tuck the top of the jamb flashing under the flap of the water-resistive barrier at the head.

**7.4.4** Use firm pressure to apply the self adhering flashing to promote seal to window flange and WRB. Use of a J-Roller is recommended.

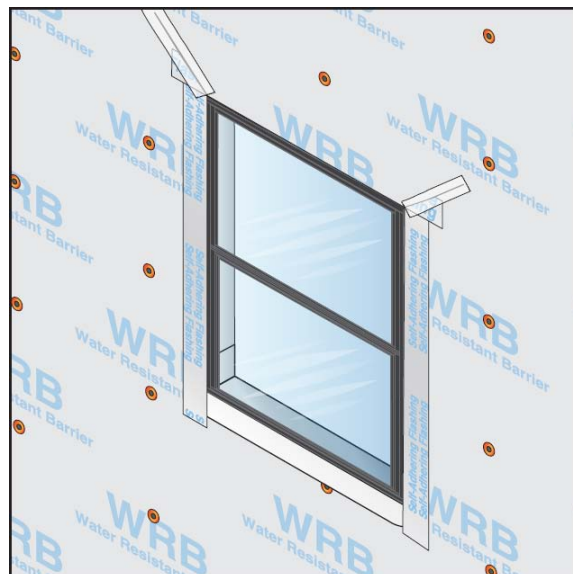
**7.4.5** Apply a piece of flashing across the head of the rough opening. The head flashing shall be cut to the width of the rough opening plus two times the roll width of the flashing, plus 50 mm (2 in).

**7.4.6** Adhere the self-adhering flashing with firm pressure (use of a J-Roller is recommended) across the head of the window on top of the mounting flange and beyond the rough opening on each side extending it 50 mm (2 in) over the outside edge of the flashing at the jambs (see Figure 18).



**FIGURE 18**

**7.4.7** Remove the previously applied tape which holds the flap of the water-resistive barrier at the head. Allow the flap to lay flat over the head flashing. Apply a new piece of sheathing tape or 100 mm (4 in) self-adhering flashing over the WRB flap and the entire diagonal cut made in the water-resistive barrier. The tape should be compressed against the WRB and the head flashing, which extends over the jamb (see Figure 19). Placing discontinuous lengths of tape across the width of the head seam between the WRB and the head flashing is acceptable, but may result in increased air infiltration around the WRB.



**FIGURE 19**



## 7.5 JAMB AND HEAD FLASHING USING MECHANICALLY ATTACHED FLASHING

**7.5.1** Apply a continuous 9 mm (3/8 in) nominal diameter bead of sealant over sheathing (wall surface) and the exterior face of the mounting flange, starting 216 mm (8 1/2 in.) above the rough opening (see Figure 20) continuing down the jambs to the bottom of the sill mounting flange.



**FIGURE 20**

**7.5.2** Cut jamb flashing to a measurement equal to twice the roll width of the flashing being used, plus the height of the rough opening, minus 25 mm (1 in).

**7.5.3** Apply jamb flashing in line with any pre-punched holes/slots in the mounting flange and cover any fastener heads (see Figure 21).

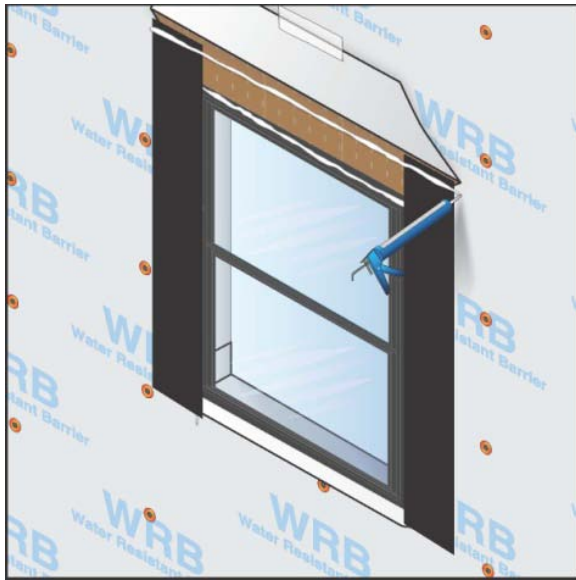


**FIGURE 21**

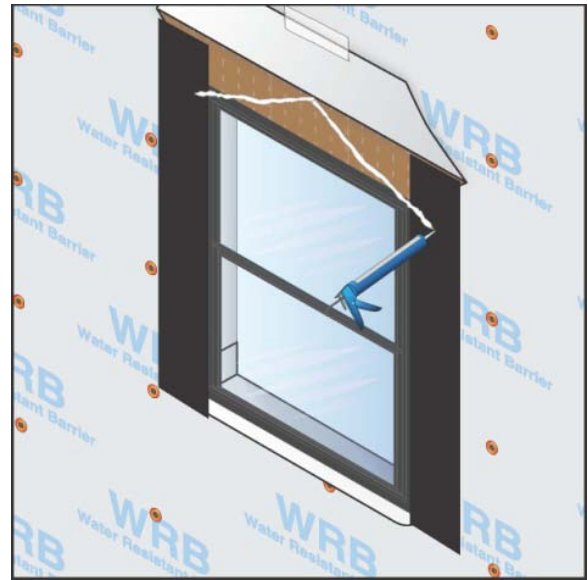
**7.5.4** Cut a piece of head flashing that is the width of the rough opening, plus two times the roll width of the flashing, plus 50 mm (2 in).

**7.5.5** Apply a continuous 9 mm (3/8 in) nominal diameter bead of sealant along the head. Apply an additional 9 mm (3/8 in) nominal diameter bead of sealant horizontally 216 mm (8 ½ in) above the rough opening in line with the top of the jamb flashing (see Figure 22) or as a sloped roof design (see Figure 22A).

**7.5.6** Apply mechanically attached flashing to head over sealants and secure with mechanical fasteners (see Figure 23).



**FIGURE 22**



**FIGURE 22A**

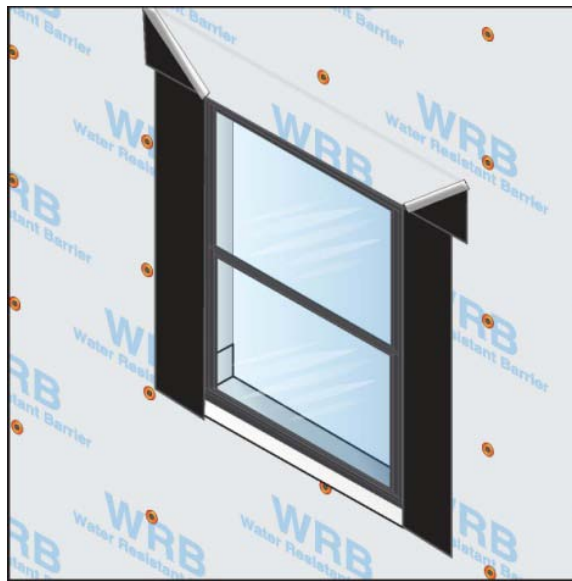
**7.5.6.1** Use fasteners (in accordance with the flashing manufacturer's recommendations) to secure mechanically attached flashing at the head. (see Figure 23). Cover fasteners with WRB or sealant whenever possible.



**FIGURE 23**

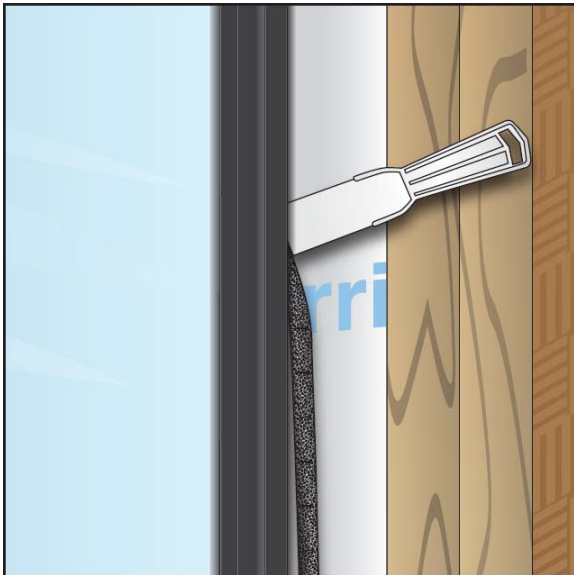
**7.6** The following steps apply when using both self-adhering and mechanically attached flashing.

Remove the previously applied tape which holds the flap of the water-resistive barrier at the head. Allow the flap to lay flat over the flashing. Apply a new piece of sheathing tape or 100 mm (4 in) self adhering flashing over the WRB flap and the entire diagonal cut made in the water-resistive barrier. The tape should be compressed against the WRB and the head flashing, which extends over the jamb (see Figure 24). Placing discontinuous lengths of tape across the width of the head seam between the WRB and the head flashing is acceptable, but may result in increased air infiltration around the WRB.

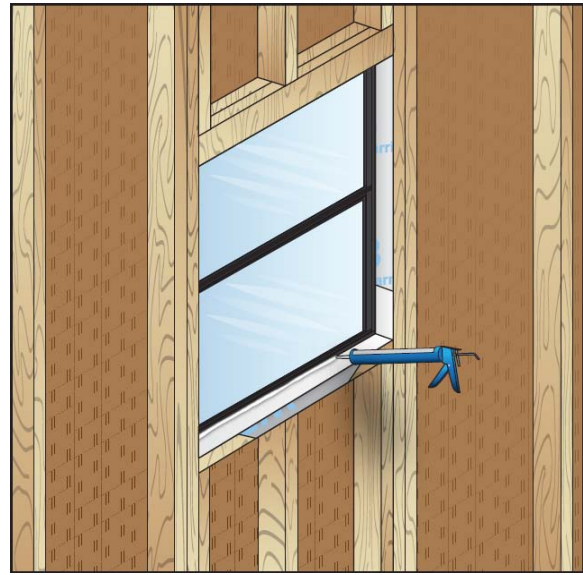


**FIGURE 24**

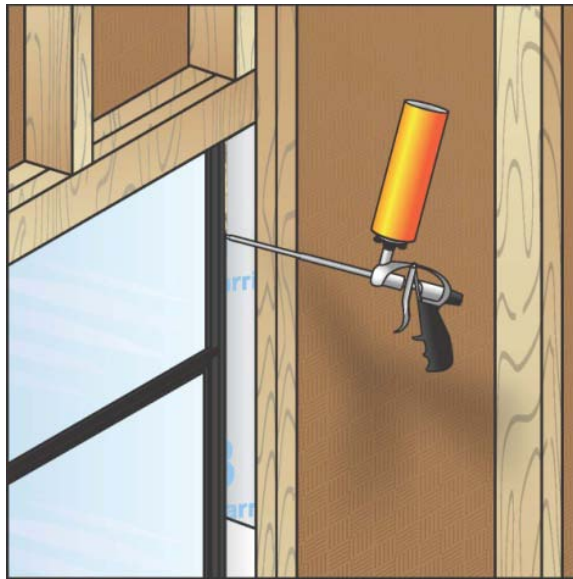
**7.7** At the interior, using a sealant recommended in Section 5.4 and appropriate bond breakers or backer rod, apply a bead of sealant (see Figures 25 and 26), or low expansion aerosol foam sealant conforming to Section 5.4.4 (see Figure 27), or other window manufacturer approved material between the window and the rough opening on all sides to form a continuous air seal.



**FIGURE 25**



**FIGURE 26**



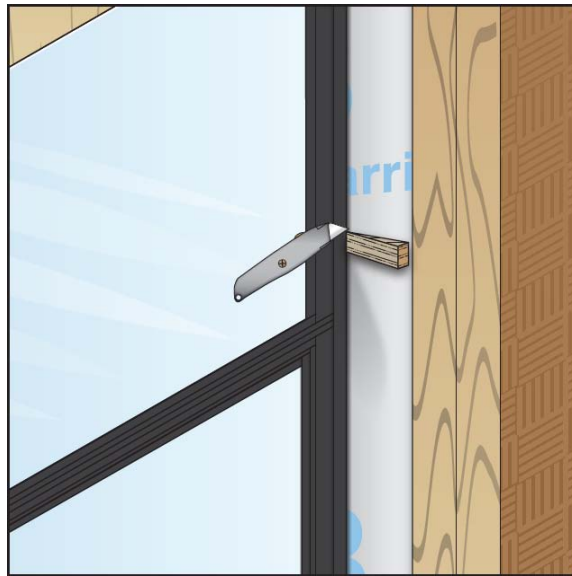
**FIGURE 27**

**7.7.1** For drainage sill pan methods, this interior seal effectively forms a back dam to prevent water intrusion into the interior, thus the integrity (adhesive bond strength) of this seal is critical. A raised upturned leg on the interior plane of the sill pan made from a rigid material can also be used, if properly air sealed. If a rigid or semi-rigid sill pan was used, recheck the seal between the sill of the window and the upturned leg of the sill pan and reseal as needed (see Figure 28).



**FIGURE 28**

**7.7.2** In cases where shims, clips, or anchoring devices cause interference with the application of the interior air and water seal, trim, remove or take steps necessary to seal such obstructions to allow for a continuous air/water seal (see Figure 29). In all cases make sure the entire perimeter joint has been sealed, creating an air/water tight condition.



**FIGURE 29**

**7.7.3** To ensure adequate protection against extreme wind driven water, it is critical that the perimeter interior air and water seal between the window and the sill pan flashing is able to withstand this pressure load without air and water leakage. Special caution needs to be used when applying perimeter air and water seals to the interior corners.

---

## **8.0 POST INSTALLATION PROCEDURES**

---

**8.1** Verify that the window frame and sash are installed plumb, level, square and true, within the specified tolerances (see Section 6.0).

**8.2** Check of Operable Elements – Verify that the operable sashes move freely within their frames and that weather stripping or compressible seals make full contact with mating surfaces.

**8.3** Verify that operable hardware such as locks, cranks, latches and hinges operate smoothly and that all locking mechanisms engage and operate properly.

**8.4** Verify that all accessories and other components of the fenestration product assembly are present, such as screens and hardware as applicable.

**8.5** Verify that Drainage holes are free from any blockages or obstructions.

---

## **9.0 KEYWORDS**

---

**9.1** Flashing; Sealant; Sill pans; Water-resistive barrier (WRB); Window; Installation; Mount flanges; Air seal.

---

## **APPENDIX A**

---

**A1.0** This appendix provides users of this standard practice with general guidelines for determining which entities involved in construction projects are typically responsible for various tasks or functions. These guidelines are informative only and are not intended to be mandatory. It is recommended that specific responsibilities for any given project be agreed upon by all involved entities, and be documented in applicable project contracts.

### **A2.0 GENERAL CONTRACTOR / DESIGN PROFESSIONAL**

The General Contractor/Design Professional is typically responsible for the following:

**A2.1** The necessary coordination of all trades.

**A2.2** The proper sequencing of construction activities.

**A2.3** Ensuring that all framed rough openings of the correct size, square, plumb and true, per Section 6.1.1.2.

**A2.4** Remediating any discrepancies identified by the Installation Contractor during the pre-installation inspection described in Section 6.1.1.

**A2.5** Determine and specify appropriate performance requirements of the window units as required by local code per Section 4.6.

### **A3.0 INSTALLATION CONTRACTOR**

The Installation Contractor is typically responsible for the following:

**A3.1** Conducting the pre-installation inspection of the framed opening per Section 6.1.1 and notifying the General Contractor of any discrepancies.

**A3.2** Installing the WRB per Section 6.1.2 and 6.2.

**A3.3** Installing the window per Section 7.0.

**A3.4** Verifying the window is properly installed per Section 8.0.

### **A4.0 WINDOW MANUFACTURER**

The Window Manufacturer is typically responsible for the following:

**A4.1** Providing window products that are designed to comply with the design pressure and wind load requirements specified by the General Contractor/Design Professional for the project.

**A4.2** Providing suitable instructions for proper window installation.

---

## Changes from FMA/AAMA 100-07 to FMA/AAMA 100-12

---

- Various editorial changes were made
- Added new Sections 1.6, 1.8, 1.9, 1.10 and 1.11
- Removed reference to AAMA Glossary
- Added definitions of “Compatibility”, “Flashing”, “Mounting Flange”, “Sealant, Aerosol Foam”, and “Shim”
- Changed use of “fenestration” to “window” throughout
- Removed old Section 4.7 regarding installer having a working knowledge for installation and application of sealants
- Removed old Section 5.3, “Construction Sequence”
- Added new Sections 5.4.2, 5.4.3, 5.4.4, 5.5.5, 5.5.6 and 5.6
- Added width requirement to Section 6.1.2
- Added statement regarding WRB installation after window installation to Section 6.2
- Added new Section 6.2.4
- Removed old Section 6.2.2 regarding cladding shall be applied with a weep screen after installation of second layer of WRB
- Removed old Section 7.2.1 regarding steps if WRB was not previously modified
- Added new Figures throughout
- Added new Section 7.1 (and subsections)
- Removed old Section 7.2.2
- Added width requirement and maximum self-adhering depth measurement to Section 7.2.3
- Added new NOTE 1
- Added reference to manufacturer instructions and AAMA 711 in Section 7.4.1
- Added new NOTE 3
- Changed measurements for top end of flashing adherence in Section 7.4.3
- Removed old Section 7.2.9.6 regarding application of primer to exposed OSB
- Removed minimum roll width from old Section 7.2.10, “Jamb and Head Flashing Using Mechanically Attached Flashing”
- Added new Section 7.4.7
- Added sloped roof design option to Section 7.6.5
- Added new Appendix A



**Fenestration Manufacturers Association**

**11445 Moccasin Gap Road**

**Tallahassee, FL 32309**

**PHONE (850) 668-8813 FAX (850)224-5283**

**WEBSITE [www.fmausaonline.org](http://www.fmausaonline.org)**



**American Architectural Manufacturers Association**

**1827 Walden Office Square, Suite 550**

**Schaumburg, IL 60173**

**PHONE (847)303-5664 FAX (847)303-5774**

**EMAIL [webmaster@aamanet.org](mailto:webmaster@aamanet.org)**

**WEBSITE [www.aamanet.org](http://www.aamanet.org)**